

## SPECIFICATIONS & OPERATING INSTRUCTIONS

OPERATING SHUT HEIGHT:	5-1/2" (139.7mm)
MIN. SHUT HEIGHT:	5-5/16" (134.9mm)
UNIT OPEN HEIGHT:	5-7/8" (149.2mm)
DIE HEIGHT:	2-19/32" (65.9mm)
MATERIAL FEED CLEARANCE:	7/32" (5.5mm)

UNIT CAP.:	1/16" (1.6mm) to 1/4" (6.4mm) radius 14 GA. mild steel (1.9mm) .032 stainless steel (.81mm)
UNIT CAP.:	5/16" (7.9mm) to 1/2" (12.7mm) radius 10 GA. mild steel (3.4mm) 16 GA. stainless steel (1.6mm)
RADIUS SIZES:	SET #1-1/16, 1/8, 3/16 & 1/4" rad. (1.6, 3.1, 4.8, 6.4mm) SET #2-5/16, 3/8, 7/16 & 1/2" rad. (7.9, 9.5, 11.1, 12.7mm)

# 4000

## Radius Unit

For Radii from 1/16" (1.6mm)  
to 1/2" (12.7mm)

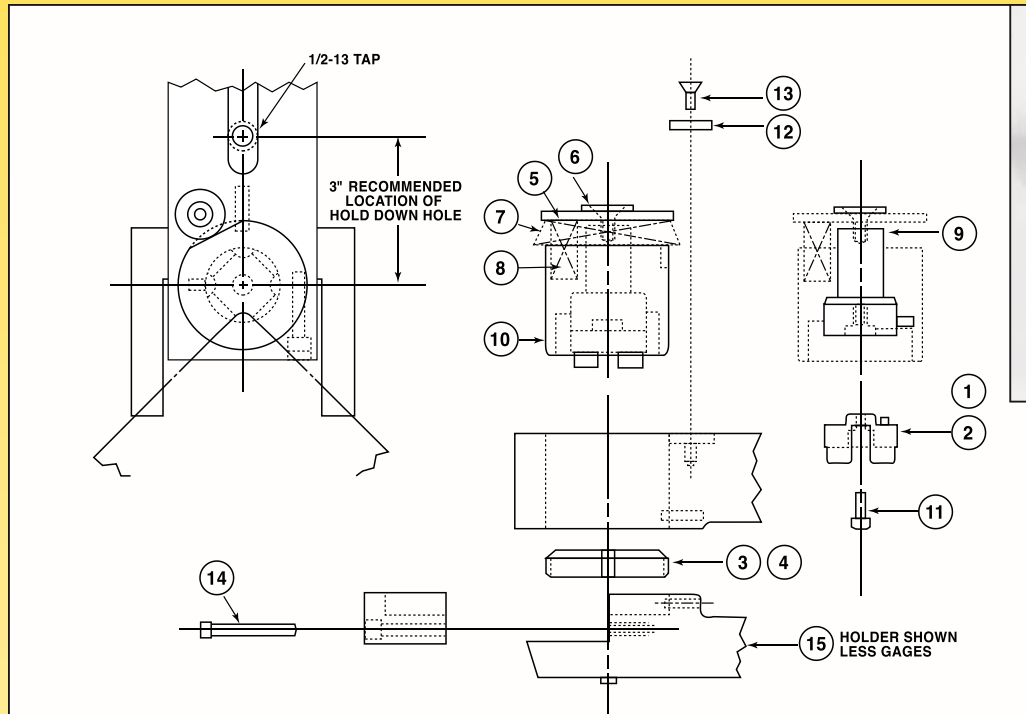

The UniPunch 4000 Unit is designed to radius trim the corners of parts (e.g. in manufacturing signs, road markers or cover plates).

This stand-alone radius unit is furnished complete with built-in squaring guides for gauging 90 degree part blanks. Two punch and die sets are available to produce eight common radii. See specifications for Set #1 or Set #2.

Radius sizes can be selected simply by rotating the punch and die assembly. The die clearance is preset for trimming mild steel up to 10 gauge thick.

Note: Custom and metric radii sizes are available upon request. Contact the UniPunch Sales Department for a quote.



4000 Radius Tool  
Punch and Die

ITEM	DESCRIPTION	PART No.
A	Unit Complete with Punch & Die Sets for four standard radii with Set #1 - 1/16", 1/8", 3/16" and 1/4" Radius	4000-1
B	Unit Complete with Punch & Die Sets for four standard radii with Set #2 - 5/16", 3/8", 7/16" and 1/2" Radius	4000-2
C	Unit Complete with Punch & Die Sets for eight standard radii with Sets #1 & 2	4000
1	Punch for radii from 1/16" thru 1/4"	4025-100
2	Punch for radii from 5/16" thru 1/2"	4050-100
3	Die for radii from 1/16" thru 1/4"	4025-200
4	Die for radii from 5/16" thru 1/2"	4050-200
5	Punch Head	3671
6	Punch Screw	91240
7	Lifter Spring	3670
8	Stripping Spring (set of 3)	3642
9	Punch Adapter	4015
10	Guide	4035
11	Screw (Punch Tip)	91010
12	Guide Retainer	1030
13	Screw (Guide Retainer)	91220
14	Screw (Die Block) (2 Req'd)	91014
15	Special Holder Only (Including Gauging Plates)	4056

Ph: (800) 828-7061 • (715) 263-3900 • Email: info@unipunch.com • Web: www.unipunch.com